

# Application note of nHPD2

## Connection to the terminals

Notice: When reviewing the product, please confirm that this application note is the latest version.

# Connection to the terminals

Please do not lift, bend or stretch either the main or the auxiliary terminals to avoid any risk of terminal deformation or damage to the plastic case housing. In addition, if the terminal area is structured such that it holds a heavy load or subject to excessive vibration, the terminals may deform and the case may be damaged by excessive weight applied to it. Please ensure external mechanical loads are supported. Main terminals are not intended to be load bearing. For example, busbar support shown in Fig. 1, is an appropriate design to protect the terminals for these external loads.

When fixing busbars to the terminals, screw bolts should be at least class 8.8 according to ISO4762. Bare or plated copper is recommended as the busbar. It is recommended to use flat washers and spring washer together to avoid loosening of screw connections.

Table 1 shows the recommended tightening torque. If a busbar is screwed to a terminal without fixing any other points, the screw torque may cause the rotation of busbar and may lead to the terminal being damaged and/or case cracking. In order to avoid this, when main terminals are connected to the same busbar, please complete prior tightening to all of the main terminals with the torque shown in Table 1 before conducting final tightening. If busbar removal is required, in order to avoid the situation that the single rigidly tightend screw bolt remains while all other bolts are removed, apply a force equivalent to the prior tightening force at each of main terminal until all the main terminal bolts are loosened. Using a longer bolt than the depth of the screw hole may cause the plastic case housing to break when the bolt is tightened. Please double check the depth of the screw hole using the datasheet as a reference and adopt a screw bolt of the appropriate length.

Fig. 1 shows an example of busbar connection. When busbars are connected to the main terminals of the module, it is strongly recommended that the busbars are fixed to a support member before connecting to the terminals in order to avoid any rotation of the busbar by the screw torque. The support member is also effective to protect the terminal from the external mechanical load in the busbar. In case of using supports to fix the busbars, the height of the supports is recommended to be equal to or shorter than that of the module. It is recommended that the module is under compression during connection.

Fig. 2 shows the maximum permissible forces on the terminal during connection to the busbars. Rotational force (moment) is not permitted. Imbalanced loads to the terminals are not recommended. When connecting the end of a busbar to a terminal where external load is to be applied to the other end of the busbar, please be aware that a large moment, proportional to the length of the busbar, may occur in the terminal. Permissible forces are only for one-time static loads during connection. Repeated loads by thermal deformation, vibration and so on, under operation, should be avoided.

It is recommended to use calibrated manual torque wrench to tighten or untighten the screw bolts. If an automatic driver is used, an electric driver using a slow rotation speed is recommended. Impact wrenches or pneumatic drivers are not permitted as these may generate excessive torque by impact load.

The threads of the screw bolts should be clean and should not be lubricated.

	Bolt	Recommended torque for prior tightening	Recommended torque for final tightening
Main terminal	M8	$4_{-3}^{+0}$ Nm	$15_{-3}^{+0}$ Nm
Auxiliary terminal	M3		$0.6_{-0.2}^{+0.2}$ Nm

**Table 1 Tightening torque for connecting to busbars**

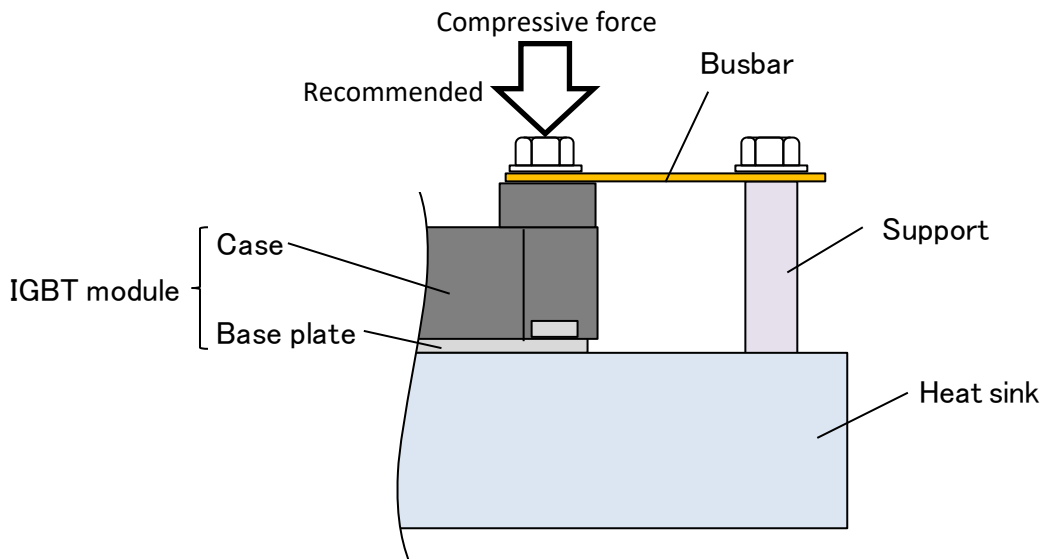

(A) Compressive load on the main terminal (recommended)

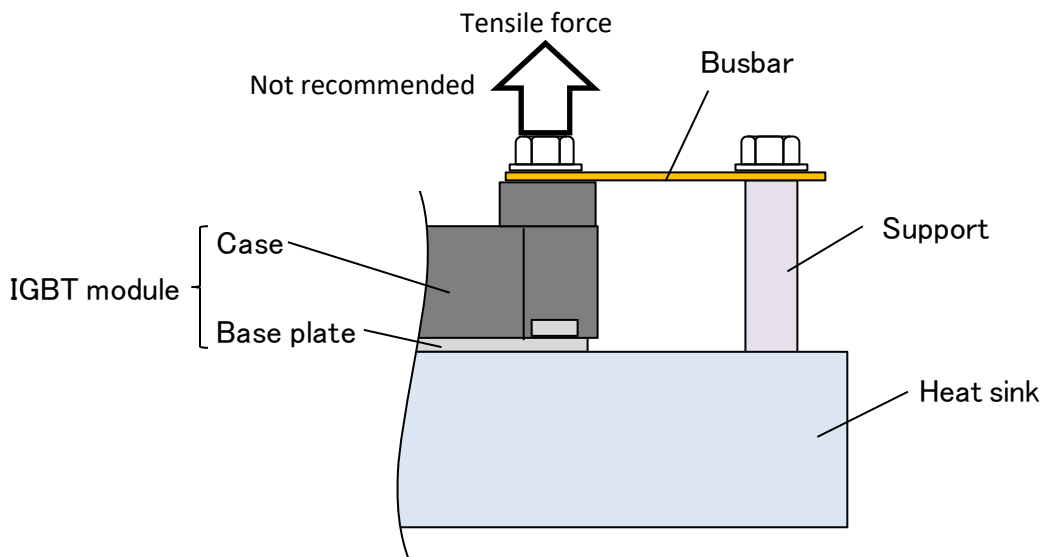

(B) Tensile load on the main terminal (not recommended)

**Fig. 1 Example of connecting terminals to the busbar**

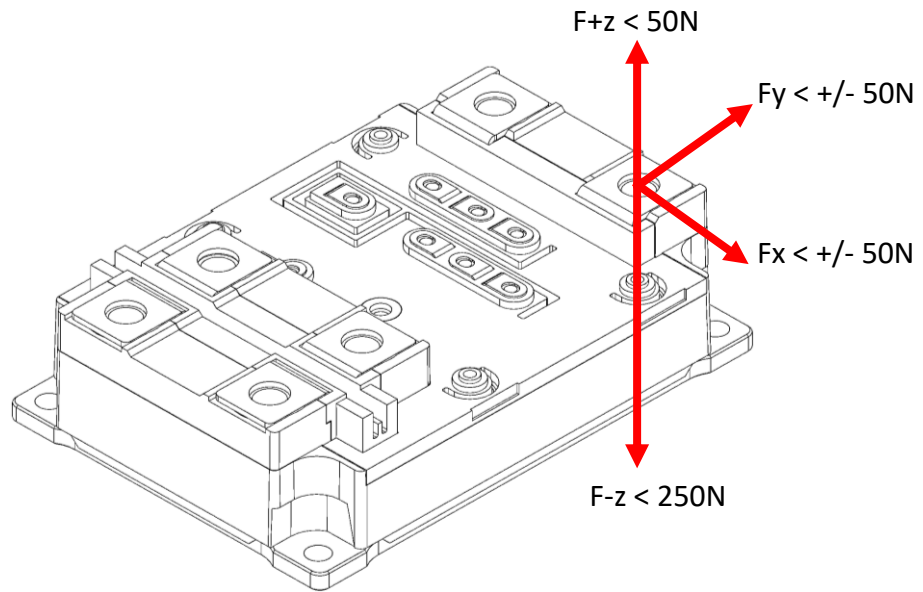

Imbalanced loads on each terminal should be avoided.  
Bending moment (rotational force) is not permitted.

**Fig. 2 Permissible forces on the main terminals during connection to busbars**